

OWNER'S MANUAL

LOPTROTTER
AUDIO ENGINEERING

EMPEROR
500

LIMITER

EMPEROR

Manual by: Rafał Smoleń

Table Of Contents

1. Introduction
2. Installation
3. Signal Path
4. Controls - Front Panel
5. Getting Started

Introduction

Thank you for choosing Looptrotter EMPEROR Limiter 500. This single channel single band dynamics processor is in fact a three-in-one device. The compressor, limiter or saturator depending on how you use it - has been designed to add colour and liveliness to your audio tracks. Thanks to separate WET and DRY knobs, it is up to you whether you add a little bit of EMPEROR's 500 „touch” to your audio, or run your signals 100% through it's processing path.

Please be aware that this is not a colourless, transparent device. EMPEROR 500 uniquely enhances apparent loudness, warmth and presence, depending on how much INPUT you use to feed the Processor. EMPEROR 500 is a creative device putting the wide spectrum of sonic possibilities.

Installation

Looptrotter Emperor 500 is dedicated to be installed in lunchbox 500 type casings. In order to use it the casing like this in rack 500 format is required. The casing is fitted with power supply and input and output ports.

For proper intallation slide the EMPEROR 500 precisely into the socket in rack 500 casing and tighten the securing screws.

LOOPROTTER
AUDIO ENGINEERING

EMPEROR

Signal Path

The input signal goes to the input amplifier, next it is split into the DRY (unprocessed) path and the WET (Processing) path. The Processor Path is fed by INPUT potentiometer, which directs the signal into the Limiter Circuit. As the signal achieves Limiter's threshold, the analog Voltage Controlled Resistor - Attenuator starts to work. The more INPUT it gets, the stronger processing will occur.

The Processor's sidechain has two EQ swithes:

1. Low freq attenuator and
2. High freq boost.

1. Low frequency shelf attenuator dips low frequencies from the sidechain signal, so the EMPEROR 500 can act more transparently and naturally on bass and signals with lots of low frequency information (eg. kick drums, bass guitars, drum loops etc.) With this option set to ON, processor's behaviour would be less affected by low frequencies, allowing you to give your signal more processing and preserve low frequencies energy and dynamics.

2. High freq boost gives additional amount of high frequencies to the sidechain signal, allowing EMPEROR 500 to become high frequency sensitive. This means that you can apply more processing to unwanted hiss on vocal tracks (and achieve a de-esser - like result) or attenuate harshness on overhead microphones.

TIMING CIRCUIT: EMPEROR 500 has three timing circuit settings: FAST, MED and SLOW.

These settings change both attack and release time of the Processor. Slower attack/release times will save the transients on signal's attack and smooth the transition that occurs when the signal dips below the threshold. It is especially useful for material with frequent peaks. Fast attack/release time makes EMPEROR 500 behave more like limiter but with extreme INPUT setting it will lead to signal saturation and audible harmonic distortion.

After processing, wet signal is amplified and goes into WET levelling section. This section is controlled by WET potentiometer. At the same time, dry signal goes into DRY levelling section, where you can set how much dry signal you want to combine with wet signal. In the end, mixed signal goes to the output.

LOOPROTTER
AUDIO ENGINEERING

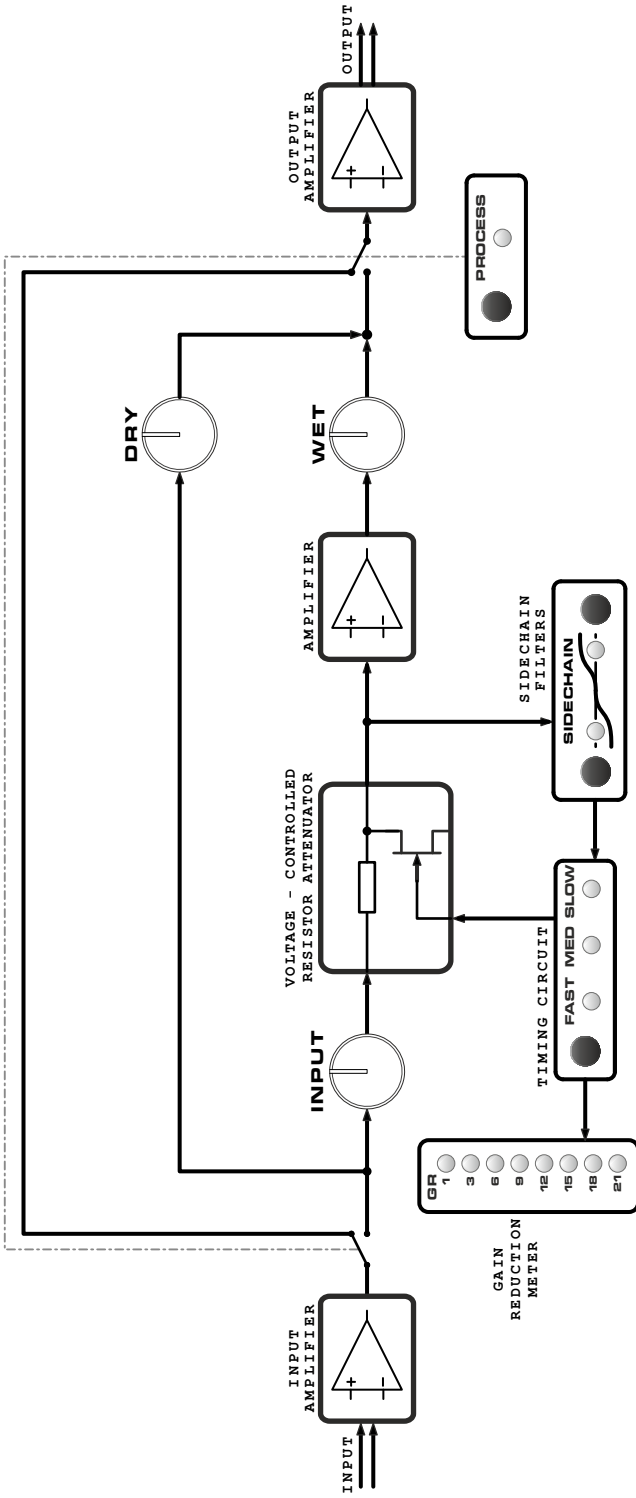

SIDECHAIN FILTERS

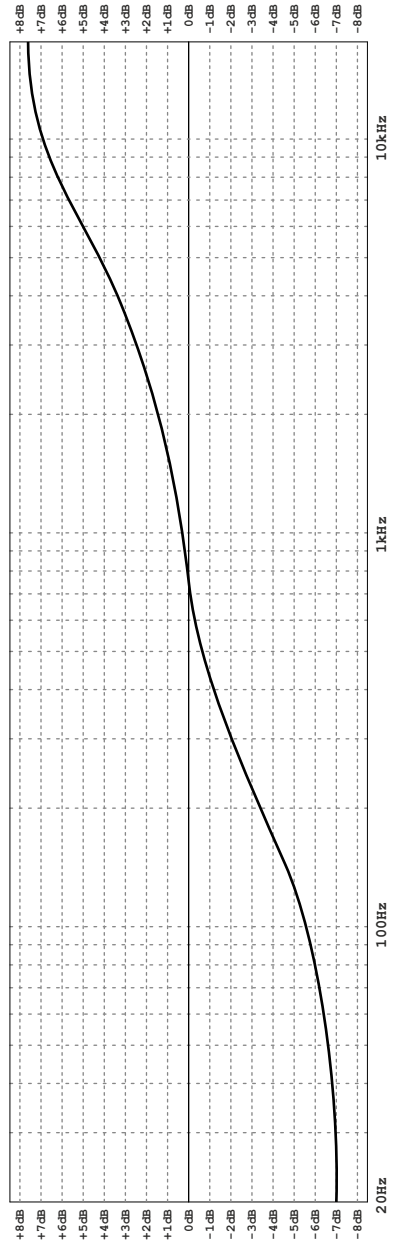

EMPEROR

Controls - Front Panel

INPUT - this knob controls signal level that goes to the Processor. Increasing the input will result in more processing (depending on the settings of the other parameters). The available range is 0 - 10. The knob is also the primary saturation controller. At lower settings, apparent loudness is not as dramatic but processing still occurs, producing a richer sound with minimal reduction of dynamic range. As INPUT is increased, the sound becomes more saturated with "sonically pleasing" distortion and perceived loudness.

SIDECHAIN - the Sidechain buttons shape the signal that controls the Processor.

With **Low Shelf** engaged, it dips low frequencies allowing the device to process bass instruments such as kick drum or bass guitar without distorting and overpumping low frequencies of the input signal.

High Shelf button boosts high frequencies of the sidechain signal and makes EMPEROR 500 to act like an analog de-esser or a very fast compressor for bright dynamic instruments.

TIMING CIRCUIT - Below you will find EMPEROR's 500 Timing Circuit button. Cycle through to switch between three factory attack/release settings:

FAST: sets Processor's attack and release times to the fastest settings, making it behave like a limiter. With this setting on, it is more likely to get rich, dense saturation of the input signal.

MED: makes EMPEROR 500 to act like a fast compressor.

SLOW: this setting makes the processor behave more like an analog compressor rather than limiter.

DRY - sets the amount of an unprocessed signal fed to EMPEROR's output. The range is 0 - 10.

WET - sets the amount of processed signal that goes to device's output. The range is 0 - 10. These two knobs determine the balance between the original and the processed signal.

The gain reduction of the signal is indicated by LED meter marked GR.

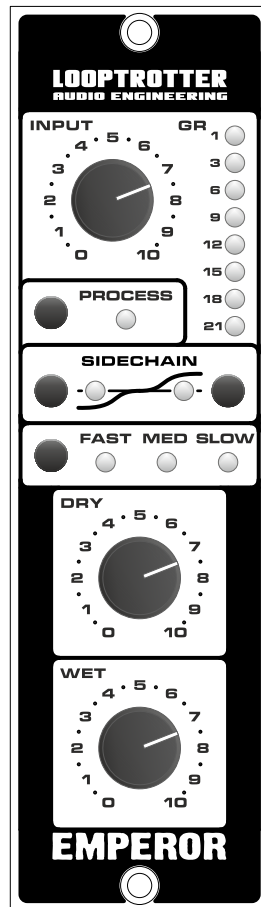

LOOPTROTTER
AUDIO ENGINEERING

EMPEROR

Getting Started

As a starting point for general enhancement, set EMPEROR's 500 INPUT knob to 5 with Low Shelf engaged and FAST release time. Set DRY knob at 10 and WET at 4. These settings offer good results under most conditions, producing more presence with a warmer sound and enhanced detail (especially with lower frequencies), while retaining the apparent dynamic range of the original signal.

The most natural warmth and tube-style distortion can be obtained with INPUT at 6, with MED release time, and both EQ shelves disengaged. Set DRY at 10 and WET at 6.

More overdrive may be obtained by setting INPUT at 8 and with FAST release time, also often with Low Shelf on. Set DRY controller at 10 and start to increase WET output level until you achieve desired amount of distortion.

For optimum results make sure the source signal is not clipped before it reaches the EMPEROR's 500 input.

Set WET at 10 and DRY at 0 in order to hear the full effect of the EMPEROR's 500 processing. Increase DRY when blending in the original signal is desired.

LOPTROTTER
AUDIO ENGINEERING

Contact:
www.looptrotter.com.pl
looptrotter@looptrotter.com.pl

Distribution:
www.mjadiolab.pl
office@mjadiolab.pl

EMPEROR

Artist:.....

Track:.....

Instrument:.....

Sesion:.....

Date:.....

Notes:.....

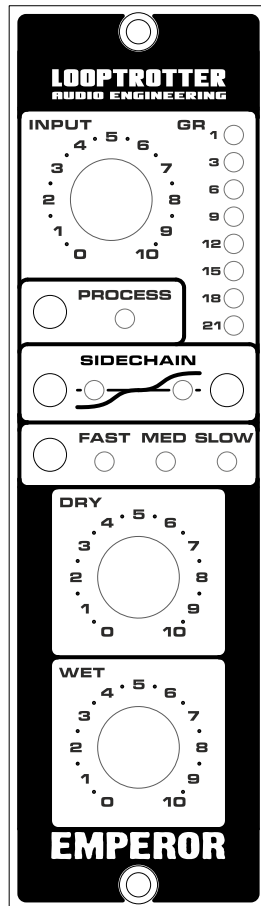

LOOPROTTER
AUDIO ENGINEERING

Contact:
www.looprotter.com.pl
looprotter@looprotter.com.pl

Distribution:
www.mjadiolab.pl
office@mjadiolab.pl

EMPEROR

LOPTROTTER
AUDIO ENGINEERING

Contact:
www.looptrotter.com.pl
looptrotter@looptrotter.com.pl

Distribution:
www.mjadiolab.pl
office@mjadiolab.pl